



# ECOPHON MASTER™ DS



Suitable for schools or other premises where strict demands are made on good acoustics and speech intelligibility. For applications where a suspended ceiling with a concealed grid is required, but individual tiles must be easily demountable.

Ecophon Master Ds has a concealed grid and symmetrical edge design, allowing easier assembly, integration of light fittings and ventilation. The ceiling has an even appearance, with the bevelled edges forming a discreet groove between the tiles. The tiles are easily demountable. The systems consist of Ecophon Master Ds tiles and Ecophon Connect grid systems, with an approximate weight of 6 kg/m<sup>2</sup>. The tiles are manufactured from high density glass wool. The visible surface is available with three different surface coatings to meet different sound absorption needs: alpha, beta and gamma. The back of the tile is covered with glass tissue. The edges are painted.

For best performance and system quality, use Ecophon Connect grid and accessories. The grid is manufactured from galvanized steel. The system is patented in the US and patent pending in Europe.

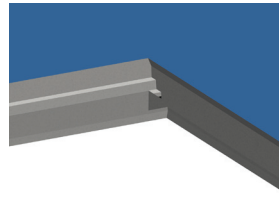

Master Ds tile

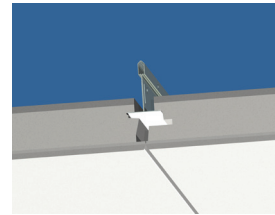

Section of Master Ds system.

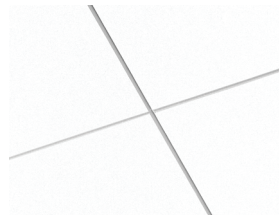

Master Ds system



The individual tiles are easily demountable

## SYSTEM RANGE

Size, mm	600 x 600
T24	•
Thickness	40
Inst. Diagr.	M236, M242

## TECHNICAL PROPERTIES

**ACOUSTIC** Sound Absorption Test results according to EN ISO 354. Classification according to EN ISO 11654, and the single value ratings for NRC and SAA according to ASTM C 423.

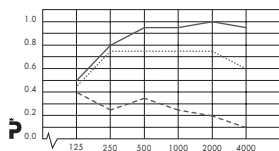
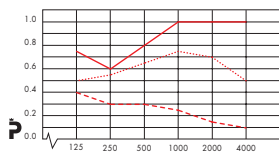

Product	Master Ds / alpha		Master Ds / beta		Master Ds / gamma	
a.d.s mm	95	200	105	200	95	200
absorption class	A	A	C	C	E	E
NRC						
SAA						
α <sub>av</sub>						

Sound Insulation  $D_{n,w}$  = 31 dB according to ISO 140-9 and evaluation according to EN ISO 717-1. CAC=33 dB according to ASTM E 1414 and evaluation according to ASTM E 413

Sound Privacy AC(1.5)=200 /alpha according to ASTM E 1111 and E 1110. /beta and /gamma are not suitable.

**ACCESSIBILITY** The tiles in size 600x600 and 1200x600 are easily demountable. The tiles in size 1200x1200 and XL sizes are demountable. Minimum demounting depth according to installation diagrams.

**CLEANABILITY** Daily dusting and vacuum cleaning. Weekly wet wiping.

**VISUAL APPEARANCE** White Frost, nearest NCS colour sample S 0500-N, 85% light reflectance (of which more than 99% is diffuse reflection). Retro reflection coefficient 63 mcd\*m<sup>-2</sup>lx<sup>-1</sup>. Gloss < 1.

**INFLUENCE OF CLIMATE** The tiles withstand a permanent ambient RH up to 95% at 30°C without sagging, warping or delaminating (ISO 4611).

**INDOOR CLIMATE** Certified by the Indoor Climate Labelling, recommended by the Swedish Asthma and Allergy Association, and can be used in rooms classified as ISO class 6 according to ISO 14644-1.

**ENVIRONMENTAL INFLUENCE** Granted the Nordic Swan eco-label. Fully recyclable.

**FIRE SAFETY** The glass wool core of the tiles is tested and classified as non-combustible according to prEN ISO 1182. The systems are classified as fire protective covering according to NT FIRE 003. See Technical properties, Fire safety.

Reaction-to-fire classification		
Country	Standard	Class
Europe	EN 13501-1	A2-s1,d0

**MECHANICAL PROPERTIES** For information regarding live load and requirements for load bearing capacity, see installation diagrams. Conditions: See Functional demands, Mechanical properties.

**INSTALLATION** Installed according to system range which includes information regarding minimum overall depth of system.

## INSTALLATION DIAGRAM (M236) FOR MASTER DS, SUSPENDED INSTALLATION

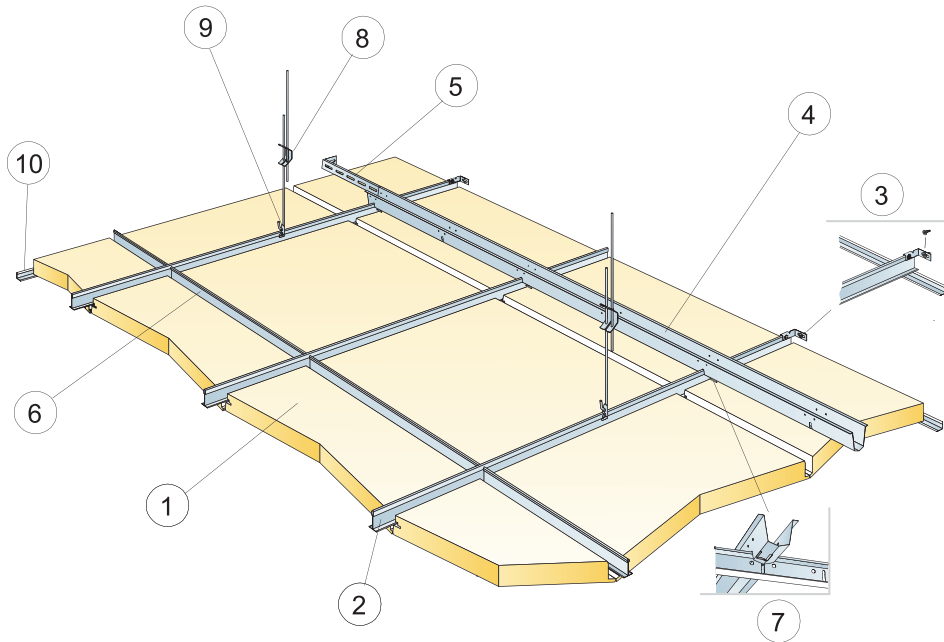

© Ecophon Group

### QUANTITY SPECIFICATION (EXCL. WASTAGE)

	<b>Size, mm</b>
	<b>600x600</b>
1 Ecophon Master Ds	2,8/m <sup>2</sup>
2 Connect T24 Main runner HD, installed at 600 mm centres	1,7m/m <sup>2</sup>
3 Connect Wall bracket for T-profiles	1 for every row of suspended Main runner HD
4 Connect Space bar, installed at 1500 mm centres (max. distance from wall 300 mm)	0,7m/m <sup>2</sup>
5 Connect Wall bracket, L=700 mm, for Space bar	1 for every row of Space bar
6 Connect T24 Cross tee, L=600 mm	2 per row of Main runner
7 Connect Space bar winch, installed one per joint Main runner/Space bar	1,4/m <sup>2</sup>
8 Connect T24 Cross tee, L=1200 mm, installed at 600 mm centres	0,7/m <sup>2</sup>
9 Connect Hanger clip	0,7/m <sup>2</sup>
10 Connect Angle trim, fixed at 300 mm centres	as required

Δ Min. overall depth of system: 140 mm

δ Min. demounting depth: 50 mm

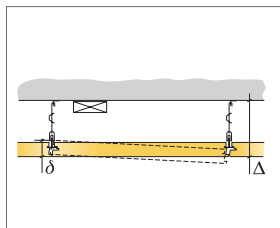

See Quantity specification

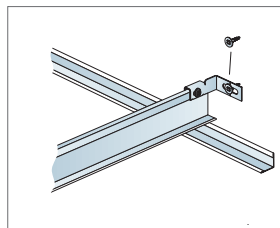

Connect Wall bracket for T-profiles

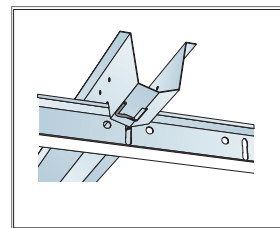

Connection between profiles with space bar winch

Size, mm	Max live load [N]	Min load bearing capacity [N]
600x600	40	160

Live load/load bearing capacity

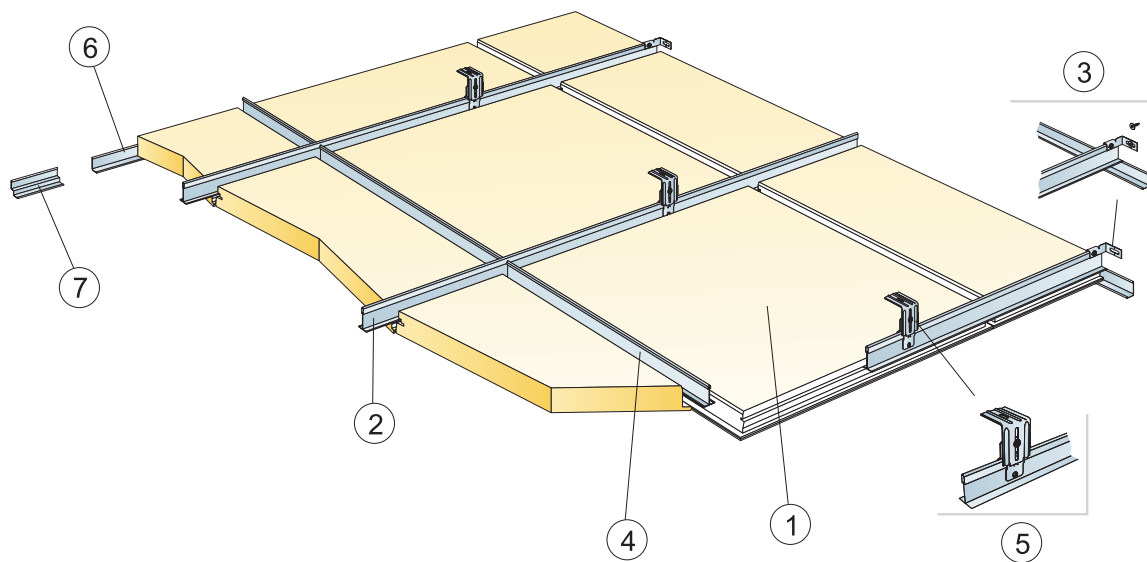

© Ecophon Group

QUANTITY SPECIFICATION (EXCL. WASTAGE)

		<b>Size, mm</b>
		<b>600x600</b>
1	Ecophon Master Ds	2,8/m <sup>2</sup>
2	Connect T24 Main runner HD, installed at 600 mm centres	1,7m/m <sup>2</sup>
3	Connect Wall bracket for T-profiles	1 for every row of suspended Main runner HD
4	Connect T24 Cross tee, L=600 mm	2 per row of Main runner
5	Connect Adjust direct bracket, installed at 1500 mm centres	1,1/m <sup>2</sup>
6	Connect Angle trim, fixed at 300 mm centres	as required
7	Connect Shadow-line trim, fixed at 300 mm centres	as required
Δ Min. overall depth of system: 95 mm		
δ Min. demounting depth: 50 mm		

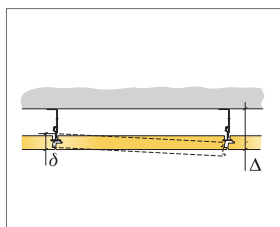

See Quantity specification

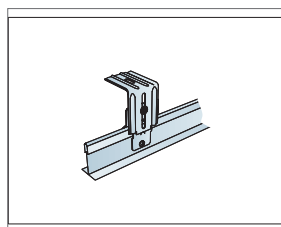

Suspension with direct bracket

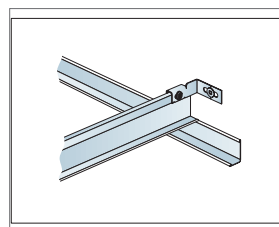

Profiles are fixed against the wall

Size, mm	Max live load [N]	Min load bearing capacity [N]
600x600	40	160

Live load/load bearing capacity